

### Typical Features

- ◆ Wide input voltage range 85-305VAC/120-430VDC
- ◆ No load power consumption  $\leq 0.25W@220VAC$
- ◆ Efficiency up to 85%(Typ.)
- ◆ Operating temperature from  $-40^{\circ}C$  to  $+85^{\circ}C$
- ◆ Switching frequency 65KHz
- ◆ Short circuit & over current protections
- ◆ Isolation voltage 4000VAC
- ◆ Altitude during operation 5000m Max
- ◆ With CE & ETL certificates
- ◆ Compliant with IEC/EN62368/UL62368
- ◆ Mini size open frame, industrial grade design
- ◆ PCB SIP mounting

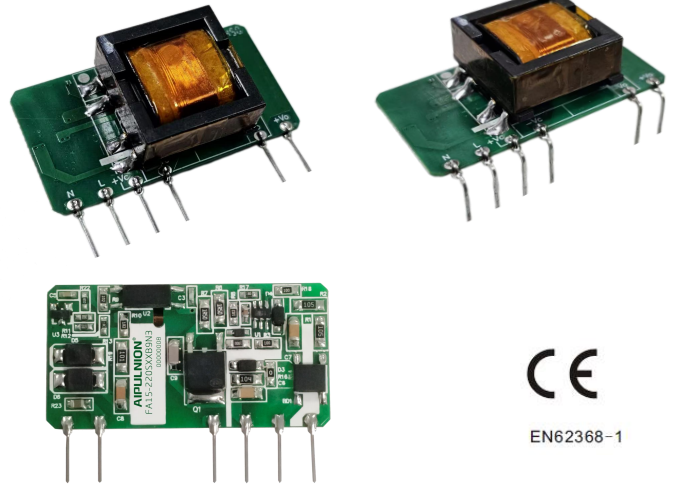

CE

EN62368-1



CONFORMS TO UL STD. 62368-1  
CERTIFIED TO CSA STD.  
C22.2 No. 62368-1

### Application Field

**FA15-220SXXB9N3(-1) Series** ----- Mini size open-frame high efficiency power supplies with global adapted input voltage range (both AC & DC available), low ripple, low temperature rise, low standby power consumption, high efficiency, high reliability, safety isolated and good EMC performance. This series of products can be widely used in the fields of Electric power, Industrial, Instrument and Smart home devices, etc. Additional circuit diagram for EMC is recommended for the application with high EMC requirement.

### Typical Product List

Certificate	Part No.	Input Voltage Range		Output Specifications			Max Capacitive Load @220VAC (uF)	Ripple & Noise 20MHz (Max) mVp-p	Efficiency @full load 220VAC (Typ.) (%)
		Nominal	Range	Power	Voltage	Current			
		(VAC)	(VAC)	P (W)	Vo(VDC)	Io(mA)			
CE/ETL	FA15-220S3V3B9N3(-1)	220	85-305	10	3.3	3000	2000	120	76
CE/ETL	FA15-220S05B9N3(-1)			15	5	3000	2000	120	77
CE/ETL	FA15-220S12B9N3(-1)				12	1250	1000	120	83
CE/ETL	FA15-220S12V7B9N3(-1)				12.7	1181	1000	120	82
CE/ETL	FA15-220S15B9N3(-1)				15	1000	1000	120	83
CE/ETL	FA15-220S24B9N3(-1)				24	625	800	150	85

Note 1: Please contact Aipu sales for other output voltages requirements of this series but not listed in this table.

Note 2: The typical value of efficiency is based on the product tested after half an hour burn-in at full load.

Note 3: "\*" indicates models currently under development.

Note 4: The full-load efficiency (% , TYP) listed in the table has a tolerance of  $\pm 2\%$ . It is calculated as the total output power divided by the module's input power.

Note 5: The suffix -1 indicates the parts with pins 90° bent.

Input Specifications					
Item	Test Condition	Min	Typ.	Max	Unit
Input voltage range	AC input	85	220	305	VAC
	DC input	120	310	430	VDC
Input frequency range	-	47	50	63	Hz
Input current	Input 115VAC	-	-	0.40	A
	Input 220VAC	-	-	0.30	
Surge current	Input 115VAC	-	-	10	
	Input 220VAC	-	-	20	
Standby power consumption	Input 115VAC	-	-	0.25	W
	Input 220VAC	-	-		
Leakage current	-	0.5mA TYP/230VAC/50Hz			
Recommended external fuse	-	1-3.15A/300VAC Slow-blow fuse			
Hot-plug	-	N/A			
ON/OFF Control	-	N/A			

Output Specifications						
Item	Test Condition	Min	Typ.	Max	Unit	
Voltage accuracy	Full input voltage range, any load	-	±2.0	±3.0	%	
Line regulation	Nominal load	-	-	±1.0	%	
Load regulation	Nominal input voltage, 20%~100% load	-	-	±1.0	%	
Minimum load	Single Output	0	-	-	%	
Temperature drift coefficient	-	-	-	±0.03	%/°C	
Turn-on delay time	Input 115VAC (full load)	-	-	1500	mS	
	Input 220VAC (full load)	-	-			
Power-off hold-up time	Input 115VAC (full load)	-	50	-	mS	
	Input 220VAC (full load)	-	80	-		
Dynamic response	Overshoot range	25%~50%~25%	-5.0	-	+5.0	%
	Recovery time	50%~75%~50%	-	5.0	-	mS
Output overshoot	Full input voltage range	≤10			%Vo	
Short circuit protection		Continuous, self-recovery			Hiccup	
Over current protection	Input 220VAC	130%Io	-	200%Io	mA	
Ripple & Noise	5%-100% load, 20MHz bandwidth	-	50	150	mVp-p	

Note 1: Ripple and noise are measured using the parallel cable method. Please refer to the "Ripple & Noise Test Instructions" below for detailed methodology and setup.

General Specifications					
Item	Test Condition	Min	Typ.	Max	Unit
Switching frequency	-	-	65	-	KHz
Operating temperature	Refer to the Temperature Derating Graph	-40	-	+85	°C

Storage temperature	-		-40	-	+105	
Soldering temperature	Wave soldering		260±4℃, time 5-10S			
	Manual soldering		360±8℃, time 4-7S			
Relative humidity	-		10	-	90	%RH
Isolation voltage	I/P-O/P	Test 1min, leakage current <5mA	4000	-	-	VAC
Insulation resistance	I/P-O/P	@ DC500V	100	-	-	MΩ
MTBF	MIL-HDBK-217F@25℃		300	-	-	K Hours
Safety standard	-		IEC/EN62368			
Vibration	-		10-55Hz, 10G, 30Min, along X, Y, Z			
Safety standard	-		CLASS II			
Weight & Dimensions	Part No.		Weight (Typ)		Dimensions L x W x H	
	FA15-220SXXB9N3(-1)		15g		45.00x23.00x15.00 mm 1.772×0.906×0.591 inch	

### EMC Performance

Items		Test Standard	Performance/Class	
EMC	EMI	CE	CISPR32/EN55032 CLASS B (with the Recommended Circuit 2)	
		RE	CISPR32/EN55032 CLASS B (with the Recommended Circuit 2)	
	EMS	RS	IEC/EN61000-4-3 10V/m Perf. Criteria A (with the Recommended Circuit 1)	
		CS	IEC/EN61000-4-6 10Vr.m.s Perf. Criteria A (with the Recommended Circuit 1)	
		ESD	IEC/EN61000-4-2 Contact ±6KV / Air ±8KV Perf. Criteria B	
		Surge	IEC/EN61000-4-5 ±2KV Perf. Criteria B (with the Recommended Circuit 2)	
		EFT	IEC/EN61000-4-4	±2KV Perf. Criteria B
				±4KV Perf. Criteria B (with the Recommended Circuit 2)
Voltage dips & interruptions	IEC/EN61000-4-11	0%~70% Perf. Criteria B		

### Product Characteristics Graphs

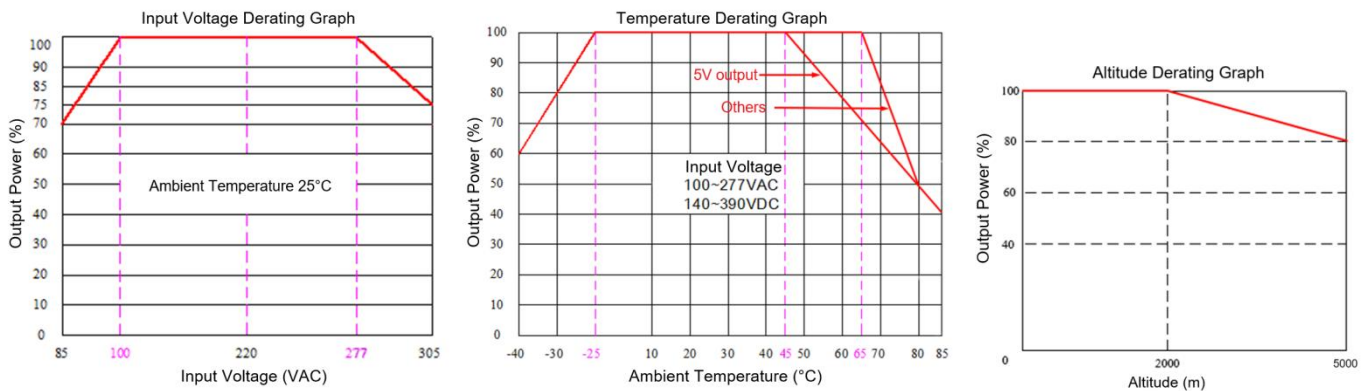

Note 1: The output power should be derated based on the input voltage derating graph at 85~100VAC//120~140VDC & 277~305VAC/390~430VDC.

The output power of FA15-220S05B9N3(-1) should be derated at the temperature >45°C.

Note 2: This product should operate under the condition of natural air, please contact us if it could be used at a closed space.

Note 3: ETL certification allows the operating temperature 80°C Max, TUV CE-LVD certificate allows the operating temperature 85°C Max.

**Recommended Circuits for Application**

**1. Typical application circuit diagram**

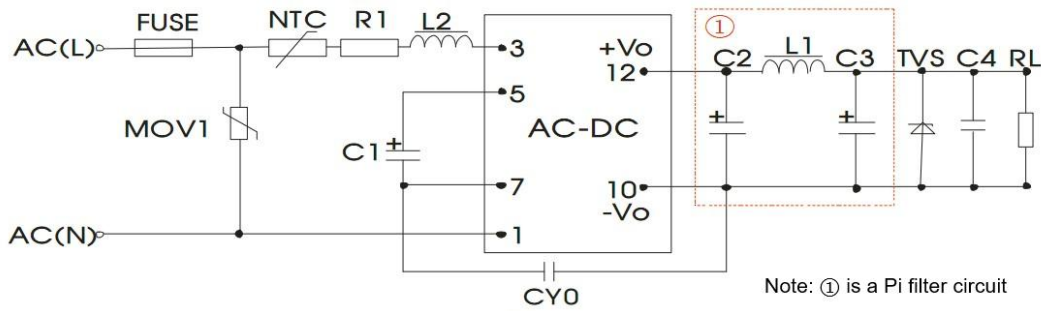

Note: ① is a Pi filter circuit

**Figure - Circuit 1**

Part No.	C1 (*)	C2 (*)	L1 (*)	C3 (*)	C4	L2	NTC	CY0	FUSE (*)	TVS
FA15-220S3V3B9N3(-1)	33uF /450V	1000μF/10V	2.0uH /4A	680μF/10V	0.1μF/ 50V	4.7mH /0.5A	5D-9	Y1/ 102M/ 400V	3.15A/ 300V Slow-blow fuse	SMBJ7.0A
FA15-220S05B9N3(-1)		470μF/16V		220μF/16V						SMBJ20A
FA15-220S12B9N3(-1)				220μF/16V						SMBJ20A
FA15-220S12V7B9N3(-1)				220μF/16V						SMBJ20A
FA15-220S15B9N3(-1)				220μF/25V						SMBJ20A
FA15-220S24B9N3(-1)				220μF/35V						SMBJ30A

**Note:**

- C1: For AC input, C1 is an input filter electrolytic capacitor (required). The recommended value is 33μF/450V. For DC input, C1 acts as a bulk filter capacitor in the EMC filter (required). The recommended value is 33uF/450V.
- R1: Current-limiting resistor. The recommended value is 12 ohms, 5W.
- MOV1: Varistor. The recommended model is 10D561K/3500A.
- NTC: Thermistor. The recommended model is 5D-9.

**2. Recommended EMC circuit diagram (for higher EMC requirement)**

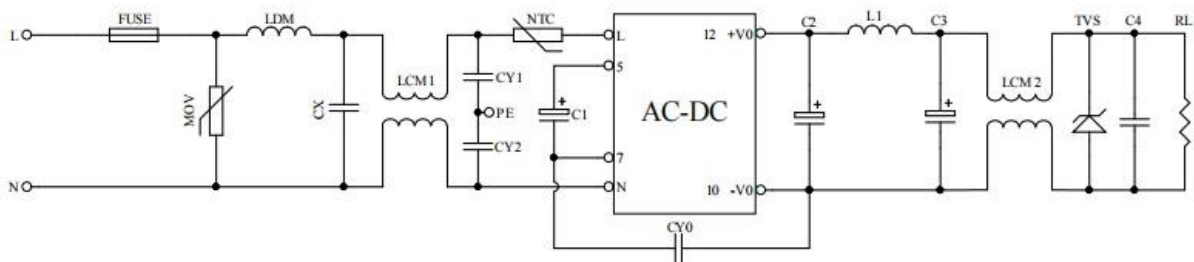

**Figure - Circuit 2/1**

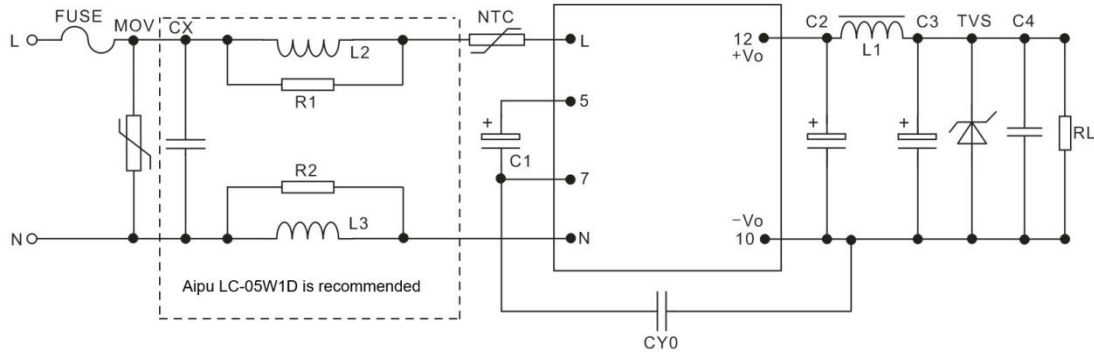
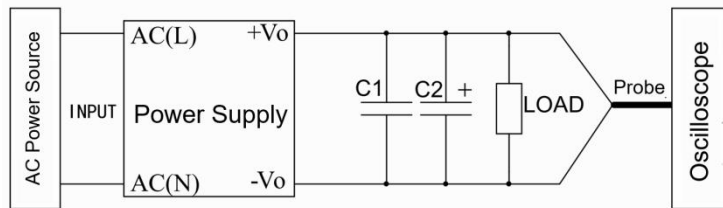

**Figure – Circuit 2/2**

FUSE	3.15A/300V slow-blow fuse, required	NTC	5D-9	R1, R2	2.2KΩ/>1/8W
MOV	10D561K/3500A	CY0, CY1, CY2	Y1/102M/400VAC	LCM2	40μH/4A
CX	X2/224K/310VAC	LDM	820μH/0.5A		
LCM1	40mH/0.5A	L2, L3	Color-ring choke 1mH/0.5A		

Note: Please refer to the typical application recommendation for all the other components which are not in above table.

**Ripple & Noise Test Instructions (Parallel-line Method, 20MHz Bandwidth)**



1. The Ripple & Noise test needs the cables in parallel, an oscilloscope that should be set at the Sample Mode, bandwidth 20MHz. 100M bandwidth probe with cap and ground removed. One polypropylene capacitor C1(0.1μF) and one high frequency low impedance electrolytic capacitor C2(10μF) are connected in parallel with the probe.
2. Output ripple and noise test setup: Connect the input terminal of the module to the power supply, and connect the output to the electronic load via a test fixture board. Use separate sampling wires directly from the output ports for measurement. Select insulated power cables with an appropriate wire gauge based on the output current.

**FA15-220SXXB9N3 Mechanical Dimensions**

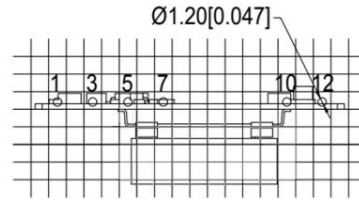
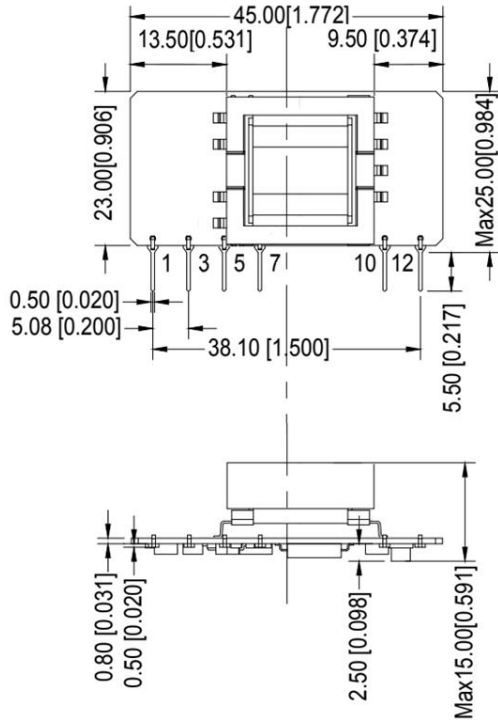

PCB layout vertical view  
Grid 2.54x2.54[0.10x0.10]

Unit: mm[inch]  
Pin diameter tolerance:  $\pm 0.10[\pm 0.004]$   
General tolerance:  $\pm 0.50[\pm 0.020]$   
The components layout is only for reference, any deviation from the actual unit should be acceptable.

**Pin-out Function Description**

Pin No.	1	3	5	7	10	12
Function	AC(N)	AC(L)	+Vcap	-Vcap	-Vo	+Vo

**FA15-220SXXB9N3-1 Mechanical Dimensions**

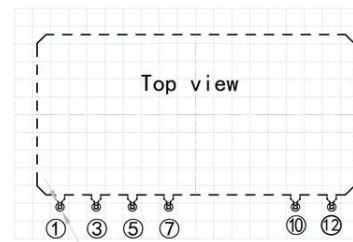
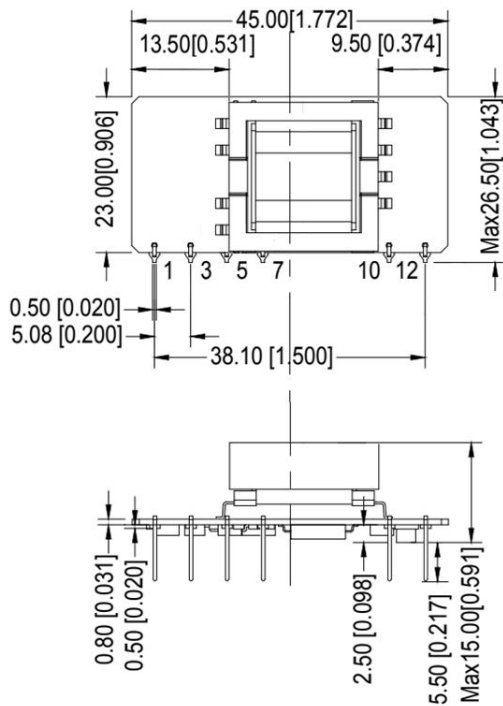

PCB layout vertical view  
Grid 2.54x2.54[0.10x0.10]

Unit: mm[inch]  
Pin diameter tolerance:  $\pm 0.10[\pm 0.004]$   
General tolerance:  $\pm 0.50[\pm 0.020]$   
The components layout is only for reference, any deviation from the actual unit should be acceptable.

**Pin-out Function Description**

Pin No.	1	3	5	7	10	12
Function	AC(N)	AC(L)	+Vcap	-Vcap	-Vo	+Vo

**Application Notice**

1. The product should be used according to the specifications, otherwise it could be permanently damaged.
2. The product performance cannot be guaranteed if it works at a lower load than the minimum load defined.
3. The product performance cannot be guaranteed if it works under over-load condition.
4. Unless otherwise specified, all values or indicators on this datasheet are tested at Ta=25°C, humidity<75%RH, nominal input voltage and rated load (pure resistance load).
5. All values or indicators on this datasheet have been tested based on Aipupower test specifications.
6. The specifications are specially for the parts listed on this datasheet, any other non-standard model performances could be out of the specifications. Please contact our technician for specific requirements.
7. Aipupower can provide customization service.

**Guangzhou Aipu Electron Technology Co., Ltd**

Address: Building 4, HEDY Park, No.63, Punan Road, Huangpu Dist, Guangzhou, China.

Tel: 86-20-84206763 Fax: 86-20-84206762 HOTLINE: 400-889-8821

E-mail: [sales@aipu-elec.com](mailto:sales@aipu-elec.com) Website: <https://www.aipupower.com>